

Hot Tender Cakes



 **fringand**
Excellence at yours service

top

 fringand



e1eac

All-electric extremely compact
multiple hearth incinerators

Low-power connection

High-performance steam
production system

optional Embedded mixed-model elevator.
charging platform / work top

This audacious system allows adjusting support according to working height needed, suppressing useless efforts **1**

The use of the charging platform is facilitated by the embedded elevator.

For works with a peel or with plaques, the supporting element is placed at the level required and so, can be used as work top.

When it is not used, the charging platform is stored under the first level in a case designed for that purpose [this position guarantees an efficient protection of the belt from condensation steam that form naturally at the upper part of the oven].



STANDARD EQUIPMENTS

- . Electro-mechanic control panel
- . All-stainless steel facade
- . Exhaust hood with steam extractor
- . Standard chamber height:
 - 180-mm usable height at lower levels,
 - 200-mm usable height at upper level.
- . Halogen lighting
- . Refractory cement tiles

OPTIONS

- . Mixed-model charging elevator / work top
- . Air inlet on 1, 2, 3, 4 or 5 levels
- . Electronic mounting plate

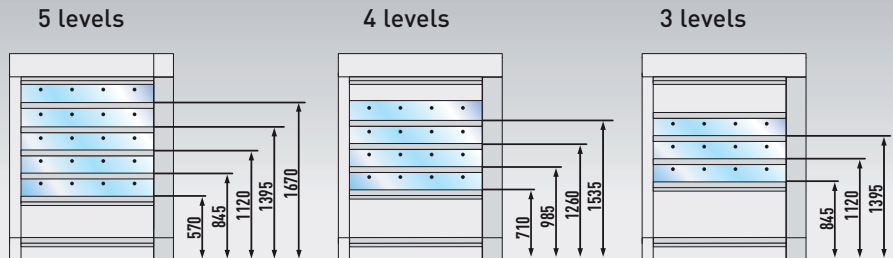
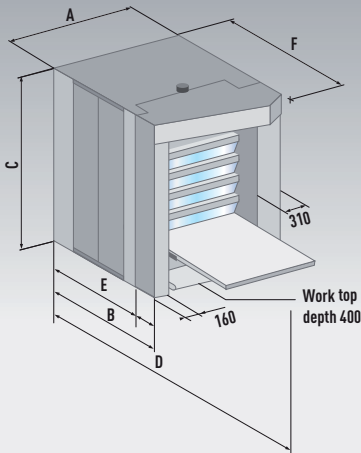

TYPE OF OVEN	NUMBER OF LEVELS	SURFACE DE CUISSON (M ²)	POWER (KW)	SIZE OF OVEN (MM)					
				A	B	C	D	E	F
12/80/3	3	2,90	13,7	1680	1540	2250	2420	1250	1750
12/80/4	4	3,85	18,0	1680	1540	2250	2420	1250	1750
12/80/5	5	4,80	22,3	1680	1540	2250	2420	1250	1750
60/120/3	3	2,20	12,6	1080	1940	2250	3220	1650	2150
60/120/4	4	2,90	16,6	1080	1940	2250	3220	1650	2150
60/120/5	5	3,60	20,5	1080	1940	2250	3220	1650	2150
90/120/3	3	3,20	16,7	1380	1940	2250	3220	1650	2150
90/120/4	4	4,30	22,0	1380	1940	2250	3220	1650	2150
90/120/5	5	5,40	27,3	1380	1940	2250	3220	1650	2150



Facilitated installation

Thanks to its reduced size, the TOPELEC oven can be placed in a 30m² shop furnace for cooking in front of customers.

The compact TOPELEC oven is a production tool with surprising capabilities.